

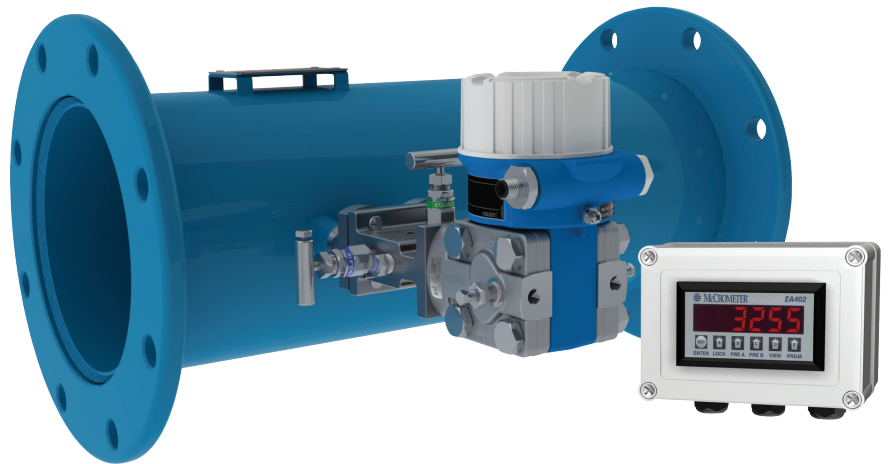

Singapore Sales Enquiry:
Email: sales@pipeline.com.sg
Tel: (65) 6570 0310

Myanmar Sales Enquiry:
Email: sales@pipeline-mm.com
Tel: (95) 9509 5758



The VM V-Cone System Flow Meter ...

Measurement Simplified.

The McCrometer VM V-Cone System flow meter is designed to make flow measurement easy!

- Small Footprint
- No Moving Parts
- For Hard-to-Fit Applications
- Designable Head Loss
- Ready to Install Right Out of the Box
- Self-Conditions Disturbed Flows
- Minimal Up or Downstream Piping Requirements

The VM V-Cone System flow meter keeps total cost of ownership where it should be...DOWN.



More than 70,000 V-Cones Installed Worldwide

25+ Years Experience

HIGH PERFORMANCE

The VM V-Cone flow meter offers great accuracy and repeatability, wide rangeability, installation flexibility and reduced maintenance in a compact all-in-one package.

ACCURACY YOU CAN COUNT ON

The key benefit to the VM V-Cone flow meter's unique design is its ability to provide reliable system accuracy of $\pm 0.5\%$ of rate over a 10:1 flow range under the most difficult flow conditions. Readings are precise and reliable, even under changing flow conditions and start/stop flows. The VM V-Cone is available for the following Municipal and Industrial applications:

- Well Water Production
- Raw Water Influent
- Filter and Pipe Galleries
- Finished Water Effluent
- Collection and Distribution Systems
- Facilities Distribution
- Cooling Water
- Reclaimed Water

SELF-CONDITIONS FLOW

The VM V-Cone flow meter's enhanced performance is due to the shape and positioning of the measuring element. The VM V-Cone flow meter's unique design centers the differential pressure cone centrally in the flow tube. This placement reshapes the flow profile, giving the V-Cone the smallest footprint of any in-line flow meter. This conditioned flow creates a low amplitude, high frequency signal that is accurate to $\pm 0.5\%$ of rate.

MAXIMUM INSTALLATION FLEXIBILITY

Due to its ability to accurately measure disturbed flow, the VM V-Cone flow meter doesn't require the same upstream or downstream straight pipe runs of many other flow meters. This key feature means the VM V-Cone flow meter can be installed virtually anywhere in a piping system or easily retrofitted into an existing piping layout. The result can be significant cost savings. It also means the VM V-Cone flow meter can fit almost anywhere other flow meters can't due to limited space or weight requirements.

LITTLE TO NO MAINTENANCE

The VM V-Cone System assures long-term performance because there are no moving parts to repair or replace. Once installed, the primary element rarely, if ever, needs to be removed from service. This leaves only the flow transmitter with the occasional recalibration over its lifetime. The V-Cone family of flow meters have a proven long life with installations exceeding 20 years without the need to be removed or re-calibrated.

PRE-PACKAGED, TESTED AND READY TO INSTALL

Start-Up and Commissioning are easy with the VM V-Cone Flow Meter. It comes wet flow calibrated and ready to install. All electronics come pre-programmed and ready to be powered and hooked into the SCADA, DCS or other control system, if desired.

FEATURES AND BENEFITS

- System accuracy of $\pm 0.5\%$ of rate
- Flow range: 10:1
- Installation: Typically 0-3 diameters upstream and 0-1 diameter downstream
- No parts to wear so little maintenance required
- HART® and Digital Protocols
- Totalizer pulse and linear 4-20mA outputs
- 3-way manifold for isolating the transmitter
- Displays both rate of flow and total flow
- Rate and total functions are independent of each other allowing for many different combinations of flow units

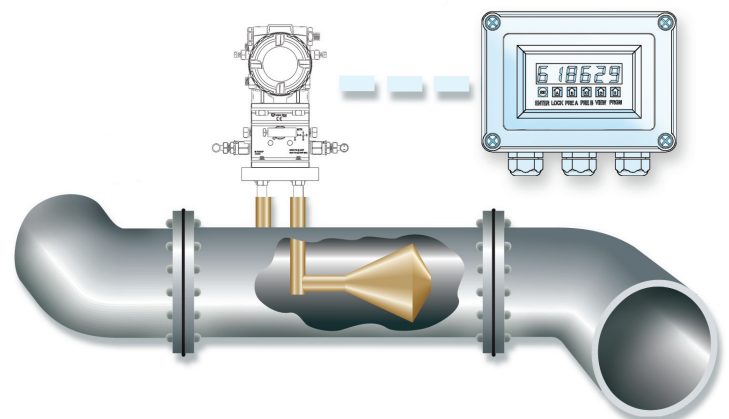

VM MODELS WITH 150psi AND 300psi PRESSURE RATING

PERFORMANCE

ACCURACY: ±0.5% of reading over standard flow range

RANGE: See dimensions chart below

HEAD LOSS: Typical ≤ 2 psi at Full Scale

MAXIMUM TEMPERATURE: (Standard Construction) 180°F constant

PRESSURE RATING: 150 psi
300 psi

POWER: 24VDC, Remote Display 110 VAC

OUTPUTS: Analog 4-20mA

OPTICALLY ISOLATED PULSE OUTPUT: For Remote Totalization

TRANSMITTER HOUSING: IP67

DISPLAY ENCLOSURE: NEMA 4X (IP66)

MATERIALS

Remote mount display includes 25 feet of power/signal cable. For additional length, please consult factory.

BODY

6-inch & larger: Fusion-bonded epoxy coated carbon steel

4-inch & smaller: All 304 stainless steel

MEASURING ELEMENT: 304 stainless steel
END CONNECTIONS

150#: 6-inch & larger: Carbon Steel AWWA Class D;
4-inch & smaller: Raised Face ANSI Class 150

300#: 6-inch and larger: Carbon Steel AWWA Class F;
4-inch & smaller: Raised Face ANSI Class 300

OPTIONS

- Other flange standards available
- Other laying lengths available

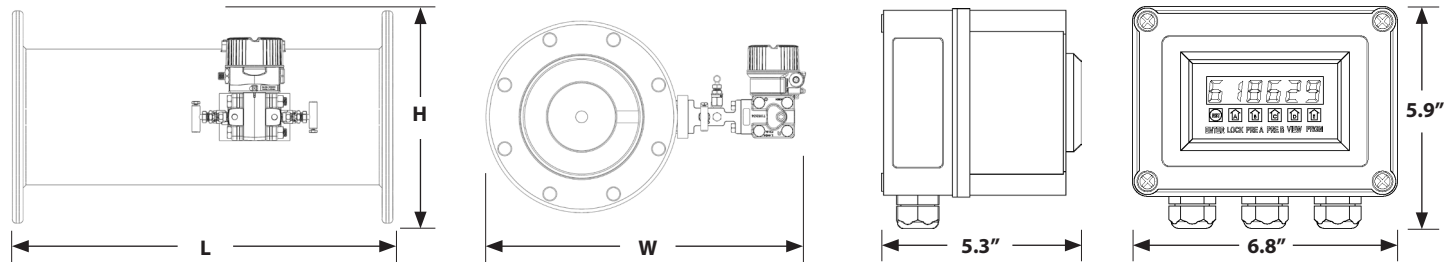
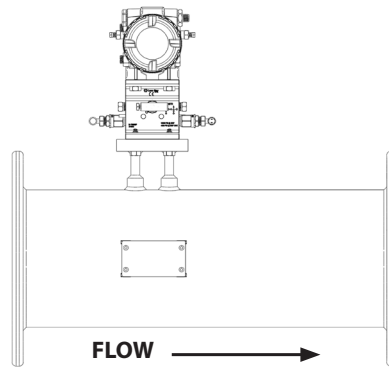

Remote Display w/ Enclosure

McCrometer reserves the right to change design specifications without notice.

FLOW RANGE CHART												
Size (in)	2	3	4	6	8	10	12	14	16	18	20	24
Applicable Standard Flow Ranges* (GPM)	10-230	20-500	40-900	80-1800	100-2250	120-2700	160-3750	200-4500	270-6000	300-7500	350-9000	560-14000
150#						150#						
Approx. Shipping Weight - lbs.	24	39	54	115	135	197	325	465	530	744	920	1254
W (width - inches)	15	16.5	17.75	20	22	24.5	27	28.5	30.75	32.5	34.75	39
H (height - inches)	14	15	13	14	15.4	16.6	19	21	23.5	25	27.5	32
L (length - inches)	12	14	16	22	26	28	30	30	30	32	36	48
No. of Bolts per Flange	4	4	8	8	8	12	12	12	16	16	20	20
300#						300#						
Approx. Shipping Weight - lbs.	29	44	90	145	220	340	430	650	820	1315	1517	1917
W (width - inches)	15.5	17	18.25	21	23	25.25	27.75	29.5	31.75	34	36.25	41
H (height - Inches)	15	16	13.8	15	16.3	17.5	20.5	23	25.5	28	30.5	36
L (length - inches)	12	14	16	22	26	28	30	30	30	32	36	48
No. of Bolts per Flange	8	8	8	12	12	16	16	20	20	24	24	24

* Meter will be 10:1 flow range standard (i.e. 400 to 40 GPM)

NOTE: Larger meter sizes, special laying lengths, other flow ranges available by special order.

The McCrometer Value Difference



For over 55 years, McCrometer has demonstrated an unyielding commitment to integrity which is reflected in our stringent flow meter calibration processes. Each flow meter is individually wet calibrated in one of our two world-class NIST traceable calibration facilities and delivered with a Certificate of Calibration.

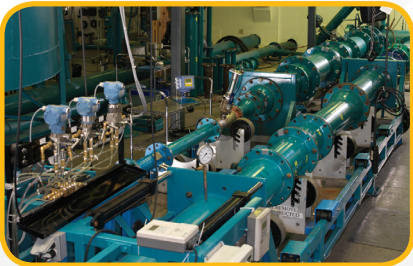

Our Hemet, California factory boasts a robust Calibration Test Lab that enables production of the most accurate and precise flow instrumentation. The test facility utilizes three gravimetric systems and two volumetric systems providing accuracy and calibration tests of flow meters from 1/2 to 20-inch diameter, with flow rates up to 4,000 gpm.



Our large volume test facility is located in Porterville, California. This facility is one of the world's largest volumetric test facilities owned by a meter manufacturer, and it offers accuracy and calibration tests of flow meters from 3 to 72-inch diameter, with flow rates up to 60,000 gpm.

REPRESENTED BY

Singapore Sales Enquiry:
Email: sales@pipeline.com.sg
Tel: (65) 6570 0310

Myanmar Sales Enquiry:
Email: sales@pipeline-mm.com
Tel: (95) 9509 5758



www.mccrometer.com

3255 West Stetson Avenue, Hemet, California 92545 USA
Phone 800-220-2279 | 951-652-6811 | Fax 951-652-3078