

WATER CONTROL SOLUTIONS

FOR BUILDING AND INDUSTRIAL SERVICES

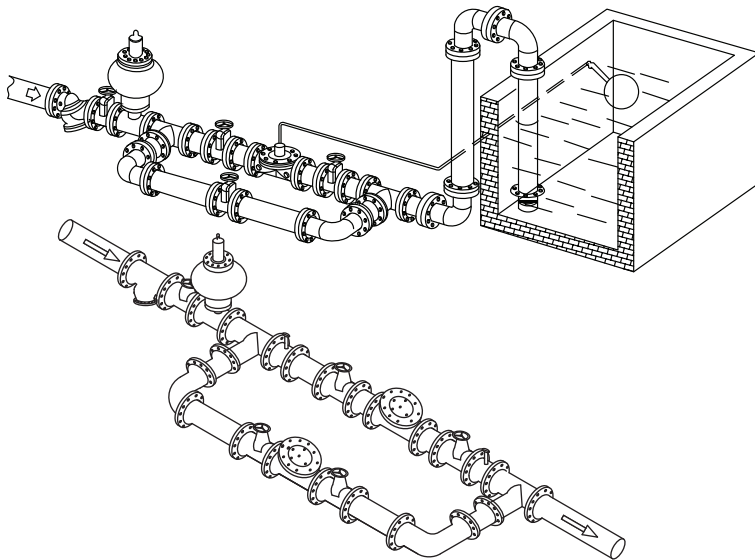

■ SOLUTIONS FOR

- Heating & Cooling Systems
- Pressure Surge Protection in pumping systems
- Reservoir and Tanks Level Control
- Pressure Reducing / Sustaining / Back Pressure Control Solutions for pressurised pipelines

■ SERVICES PROVIDED

- Supply, Installation & Commissioning
- Technical Support – Parts & Services
- After Sales Services
- Maintenance Service Contracts



PRODUCTS

- Air Relief Valve
- Differential Pressure Relief Valve
- Full Flow Foot Valve
- Float Valve
- Hydraulic Balancing Valve
- Micro-Bubble Separator
- Non-Slam Check Valve
- Pressure Relief / Pressure Sustaining / Back Pressure Valve
- Pressure Reducing Valve
- Pressure Retaining Valve
- Pulsation Dampener
- Solenoid Control Valve
- Suction Diffuser Valve
- Vortex Air Separator



Reliable and comprehensive control solutions that meet your operation requirement.

Please consult our dedicated representative for your enquiry.