

Fig. 763U
SWING CHECK VALVE, FLANGED ENDS, 200PSI

Features & Benefits

- Fire protection valve. UL listed. FM approved.
- Bolted bonnet. Horizontal swing. Renewable seat and disc.
- Flanged ends to ANSI B16.1 Class 125. Other flange types available.
- Working pressure: 200 PSI (Max. temp 63° C).
- Conform to MSS SP-71.
- Bronze trimed disc, 125 psi steam @ 232° C, 200psi. Non-shock cold water oil or gas.



Material List

Part Name	Material	ASTM SPEC.
Body	Cast Iron	ASTM A126-B
Disc	Ductile Iron	A536 65-45-12
Body Seat Ring	Cast Bronze	ASTM B62
Disc Ring(Rubber)	EPDM	Commercial
Disc Ring(Bronze)	Cast Bronze	ASTM B62
Disc Washer	Ductile Iron	A536 65-45-12
	Stainless Steel	AISI 304
Hanger Pin	Stainless Steel	AISI 410
Hanger Plug	Brass	ASTM B16
	Stainless Steel	AISI 304
Hanger	Ductile Iron	A536 65-45-12
Cover	Cast Iron	ASTM A126-B
Eye Bolt	Steel	ASTM A307-A
Disc Nut	Stainless Steel	AISI304
Gasket	Non-Asbestos	
Hex.Head Bolt	Steel	ASTM A307-A
Hexagon Nut	Steel	ASTM A563-A

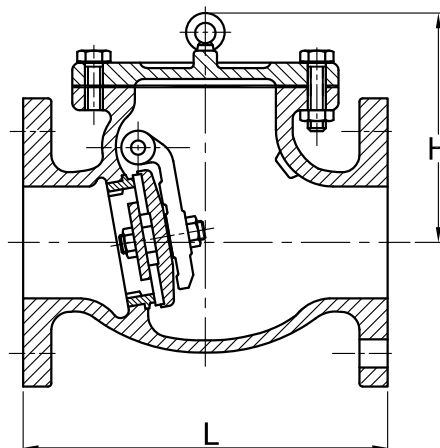

● Note: Both vertical and horizontal installation with upward flow.

Dimensions (mm / Inch)

Valve Size	65mm / 2-1/2"		80mm / 3"		100mm / 4"		150mm / 6"		200mm / 8"		250mm / 10"		300mm / 12"	
	mm	Inch	mm	Inch	mm	Inch	mm	Inch	mm	Inch	mm	Inch	mm	Inch
L			241.3	9-1/2	292.1	11-1/2	355.8	14	495.3	19-1/2	622.3	24-1/2	698.5	27-1/2
H			194	7-5/8	214	8-7/16	258	10-5/32	312	12-9/32	352	13-27/32	389	15-5/16

■ Note: Design and materials are subject to change without notice.

C-009

Revision: 2.05.2013