



## Fig. 8130 RESILIENT SEATED GATE VALVE, NRS FLANGED ENDS, 300PSI

### Features & Benefits

- Fire Protection Valve. UL listed. FM approved.
- Valves comply with AWWA C515.
- Working pressure 300PSI. Cold water pressure (Max. temp 63° C).
- Flanged ends to ANSI B16.1 Class 125. Other flange types available.
- Application: Fire protection / Air condition / Plumbing.
- Epoxy coated interior and exterior to AWWA C550.

### Material List

Part Name	Material	ASTM SPEC.
Body	Ductile Iron	A536 65-45-12
Wedge	Ductile Iron coated with EPDM	
Wedge Nut	Cast Bronze	ASTM B62
Bonnet	Ductile Iron	A536 65-45-12
Stem Ring	Cast Bronze	ASTM B62
Stem	Stainless Steel	AISI 304
	Brass	ASTM B16
Box	Ductile Iron	A536 65-45-12
Operating Nut	Cast Iron	ASTM A126-B
Washer	Stainless Steel	AISI 304
Bonnet Bolt	Stainless Steel	AISI 304
O Ring	EPDM	Commercial
Rubber Gasket	EPDM	Commercial

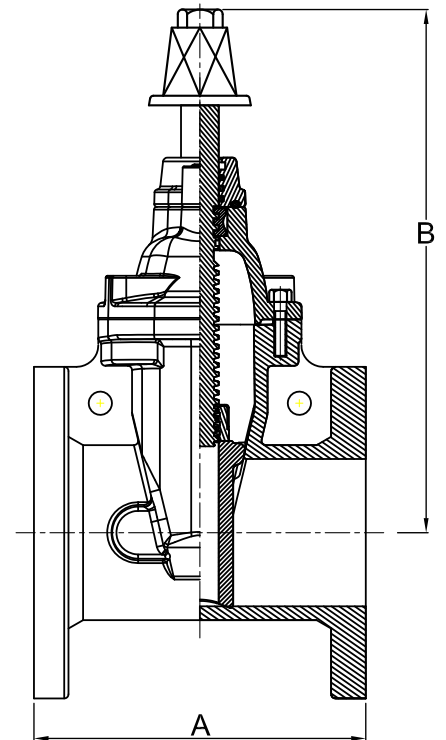
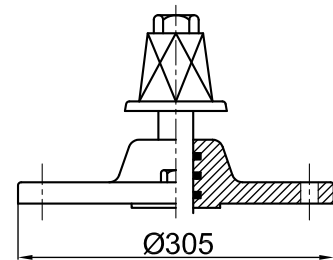

### Dimensions (mm / Inch)

Valve Size	65mm / 2-1/2"		80mm / 3"		100mm / 4"		150mm / 6"		200mm / 8"		250mm / 10"		300mm / 12"	
	mm	Inch	mm	Inch	mm	Inch	mm	Inch	mm	Inch	mm	Inch	mm	Inch
A	190.5	7-1/2	203.2	8	228.6	9	266.7	10-1/2	292.1	11-1/2	330.2	13	355.6	14
B	254	10	280	11	318	12-1/2	432	17	533	21	622	24-1/2	718	28-1/4

Note: Design and materials are subject to change without notice.  
2014-01-13.