

**Fig. 453UF**  
**FLANGED END DUCTILE IRON BODY CHECK VALVE**

**Features & Benefits**

- UL listed. FM approved.
- Ductile Iron body with EPDM seat. Stainless steel plate.
- Flanged ends to ANSI B16.1 Class 125. Other flange types available.
- Working pressure: 250 PSI, Cold water pressure(Max. temp 63° C).



**Material List**

Part Name	Material	ASTM SPEC.
Body	Ductile Iron	A536 65-45-12
Body Seal	EPDM	
Plate	Stainless Steel	ASTM A351.CF8
Spring	Stainless Steel	AISI 316
Hinge Pin	Stainless Steel	AISI 316
Washer	Teflon	
Thrust Washer	Teflon	
Plug	Mild Steel	A105-80
Square Plug	Mild Steel	A105-80
Packing	Buna"N"	

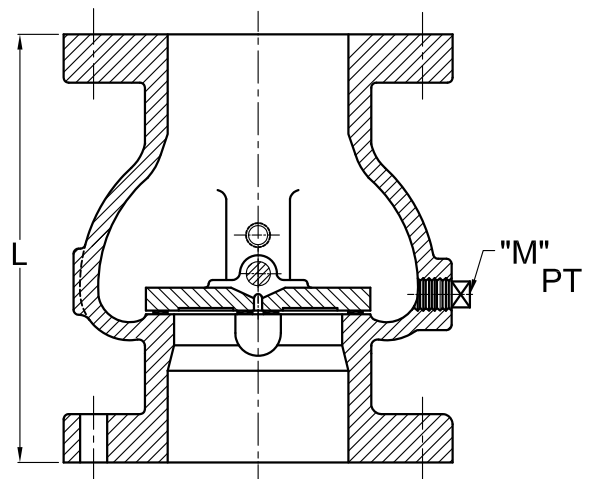

**Dimensions (mm / Inch)**

Valve Size	80mm / 3"		100mm / 4"		150mm / 6"		200mm / 8"	
	mm	Inch	mm	Inch	mm	Inch	mm	Inch
L	168.3	6-5/8	190.5	7-1/2	228.6	9	266.7	10-1/2
"M" PT		1/2"		1/2"		3/4"		3/4"

■ Note: Design and materials are subject to change without notice.

C-010

Revision: 2.05.2013