



Pressure relief with Broady Flow Control

Series 3500/3500 ASRV

Safety Relief

Flanged Valves

Broady Flow Control



BROADY
FLOW CONTROL

The Company

Broady Flow Control is an **independent Valve Manufacturer**, specialising in **Innovative** and effective **solutions** to satisfy it's increasing customer demands, challenges and problems in flow control.



MARKET SECTORS

- Naval & Marine
- Chemical & Petrochemical
- Food & Beverages
- Industrial gases
- Biotechnology
- Mining
- Fire protection
- Oil & Gas
- Pharmaceutical
- Power generation

Four key divisions

1 Relief. Safety relief. Pressure reducing & sustaining valves.



2 Valves for Naval, Marine and other specialist applications.



3 Pattern makers & Master founders of corrosion resistant copper based alloys.



4 Overhaul & Refurbishment of Broady valves and other selected valve manufacturer's products and equipment.



Introduction

There have been a number of changes and positive developments at Broady Flow Control over the past two years, including a change of ownership, new name, image and logo, in addition to other significant quality, manufacturing and system improvements.

All of these have strengthened the company and are helping to improve its long-term development and global share, through the introduction of both new products and brochures over the coming years.

The new Series 3500 ASRV (ASME coded), and Series 3500 API - relief valves.

3500 ASRV FEATURES

- ASME Section VIII, Division 1: "UV" stamp - approval.
- Designed, manufactured and tested to API 520, 526 and 527.
- CE marking to category IV.
- Excellent accumulation, blowdown and repeatable reseating characteristics.
- Total lift full nozzle design.
- Suitable for gases, liquids and vapour applications.
- Available in cast steel or stainless steel as standard, with other materials on request.
- API orifice designation from D to T.
- Sizes 1" x 2" through to 8" x 10", flanged to recognized standards.



Series 3500 Flanged Valves

The Series 3500 flanged safety-relief valves are of a full lift design offering superior flow capacities suitable for steam, gas and liquid services.

Available as either ASME Section VIII division 1 "UV Stamp" coded or to API 520 as standard.

The minimum set pressure for standard valves is 1.0 Bar, for valves fitted with balancing bellows the minimum set pressure is 1.4 Bar up to and including the J orifice reducing to 1.0 Bar for the larger sizes K to T orifices.

The Series 3500 valves can be fitted with the following optional accessories:

- **Balancing or Sealing Bellows**
- **Lifting Levers**
- **Test Gag**
- **Micro Switches**

Body

Castings of the highest quality are used in the manufacture of the Series 3500 safety relief valve.

All castings are QA certified with actual Mechanical and Chemical certification with visible identifiers stamped onto the casting.

All pressure retaining castings are hydrostatically tested to ensure pressure integrity.

Nozzle

The nozzle is of the "Full Nozzle" type; to achieve excellent seat tightness the nozzle is screwed in the base of the valve body, which allows the mating seat face of the nozzle to be optically lapped, which cannot be achieved with integral nozzle designs. The nozzle is marked for material identification allowing traceability for material test certification.

On request the nozzle can be hardened by heat treatment or supplied with a stellite facing for the more arduous services.

Disc

The disc has been designed to float within the disc holder, ensuring alignment with the nozzle; this gives the valve excellent seating and re-seating properties. The disc, which is manufactured in one piece from ARMCO 17.4 PH Stainless Steel for all ferrous valves, is optically lapped to give the best sealing characteristics. On request this material can be changed to Stainless Steel with or without stellite facing.

Quality Assurance

Safety Relief Valves listed in this catalogue are manufactured in the UK by Broady Flow Control Limited, one of Britain's best known valve manufacturers. All products are designed and manufactured in accordance to BS EN ISO 9001: 2000 and also to the QA requirements of the world's leading companies and authorities. We are also able to offer CE markings to the highest category with our safety related products, applicable to European markets only.

Balanced Bellows

The fitting of balanced bellows to the valves has two functions, it permits a constant set pressure regardless of a variable back pressure by balancing the outlet of the valve i.e. the effective diameter of the bellows is equal to the nozzle seat diameter.

Secondly, the bellows fits to the disc holder and to the guide flange and thus can be used to protect the spring and upper internals from hazardous or corrosive fluids.

The bellows can be manufactured from low carbon Stainless Steel, Monel, Inconel and Hastelloy. For NACE applications we

Characteristics of body and trim materials

Alloy steel ASME SA217 WC6

This is particularly suitable for high temperature ranges from 426°C to 538°C (800°F to 1000°F) for its excellent creep strength.

Alloy steel ASME SA352 LCC

This material is recommended for use in the temperature ranges from -30°C to -60°C (-21°F to -75°F)

Stainless steel ASME SA351 CF8

This has practically the same composition as AISI 304 with the addition of approximately 2% of molybdenum. Its corrosion resistance properties are better than those of AISI 304.

Stainless steel ASME SA351 CF8M

This is a stainless steel containing molybdenum and with a maximum carbon content of 0.03%. It may be welded without losing its corrosive resistance.

This type of steel is used when a resistance similar to that of AISI 316 is required and it is not possible to anneal the pieces after welding.

Carbon steel ASME SA216 WCB

This is particularly suitable for fluids such as air, saturated or superheated steam, non-corrosive gases and temperatures from -29°C to 426°C (-20°F to 800°F).

ASTM A 182-F316 (AISI 316) Stainless Steel

This is the material normally used in the manufacture of the nozzle and disc for the excellent corrosion resistance properties.

ASTM A 182-F304 (AISI 304) Stainless Steel

This has the same characteristics as AISI 316 stainless steel and is recommended for use with low temperature. It has good corrosion resistance properties.

Bronze to BS1400 LG2 and 4

A copper based metal with good resistive properties for water, seawater and oxygen services.

Aluminium Bronze to BS1400 AB2

Another copper based metal with excellent resistive properties against seawater services. The addition of Aluminium and Nickel gives increased strength and superior corrosion resistance over bronze.

recommend the use of either Monel or Inconel 625 to give the best material resistance and life expectancy for this service.

Blowdown Ring

The blowdown ring is used for compressible fluids (gases and vapors) and its function is to control contemporaneously the blowdown and the overpressure, in order to avoid hammering of the disc against the seat.

The ring is screwed on the nozzle with a fine thread and has a notched edge so that its position may be adjusted from outside in relation to the disc holder and locked.

When the ring is in contact with the cone-shaped part of the disc holder, the disc quickly reaches full lift with very little overpressure.

In such case no hammering takes place but high blowdown is reached.

In the position where there is a maximum distance between the ring and the cone-shaped section of the disc holder, the disc reaches full lift with maximum overpressure, while the reseating pressure is very near to the set pressure (i.e. the blowdown decreases). In such a position, hammering

of the disc against the seat can take place with harmful consequences for the sealing of the valve.

Adjusting the ring into position somewhere between these two, the right one for optimum valve performance will be found. In this position the ring is fixed from the outside by means of a pin.

Spring

Spring design and choice of material is critical to the correct operation of a safety valve.

Spring failure during service is potentially the greatest threat on any process plant, hence Broady Flow Control will only supply the most suitable material for our springs for any given application.

Phosphated carbon steel is the lowest specification, suitable for steam and air dependant on temperature, Tungsten steel, Stainless Steel, Inconel X750 and Monel springs are fitted for the more arduous duties.

Nameplate

Each valve is provided with a stainless steel nameplate on which the main constructional and operating details are shown.



Accessories

Bellows

As previously described, the fitting of a Bellows prevents the build up of backpressure from affecting the set point of the valve, i.e. balancing the outlet. It can also be used to prevent the fluid from entering the upper internals.

Lifting Devices

These allow the valve to be lifted manually to check that the operation of the seat and disc is satisfactory. Two options are available:

Open Lever – Where emission of product to atmosphere is acceptable

Closed Lever – Where emission of product to atmosphere is unacceptable

Open Bonnet

An open bonnet can be used to help cool the spring when used on Steam at high temperatures.

Test Gag

The gag may be screwed into the top of the cap to prevent the valve from opening; this is used to pressure test the system above the set point of the valve.

Micro Switch

A micro switch can be fitted to transmit an electrical signal to inform if the valve has lifted.

Overall dimensions: size ratings and weights for the Series 3500 flanged valves

type number (1st group)	inlet (inches)	orifice	outlet (inches)	ratings (ANSI)		overall dimensions*												approx. weights					
				inlet	outlet	A		B		C		D		E (max)				Kg	lbs				
						mm	in	mm	in	mm	in	mm	in	standard cap		lever cap							
														mm	in	mm	in						
3511D	1	D	2	150	150	115	4 1/2	105	4 1/8	12	1/2	30	1 3/16	400	15 3/4	465	18 5/16	18	40				
3531D				300																			
3551D				600																			
3562D				1 1/2		D	2	900	300	140	5 1/2	16	5/8	48	1 7/8	435	17 1/8	500	19 11/16	21	46		
3572D								1500															
3582D								2500															
3511E				1		E	2	150	150	115	4 1/2	105	4 1/8	12	1/2	30	1 3/16	400	15 3/4	465	18 5/16	18	40
3531E	300																						
3551E	600																						
3562E	1 1/2	E	2		900			300		140	5 1/2	16	5/8	48	1 7/8	435	17 1/8	500	19 11/16	21	46		
3572E					1500																		
3582E					2500																		
3511F	1 1/2	F	2		150			150		121	4 3/4	124	4 7/8	16	5/8	35	1 3/8	435	17 1/8	500	19 11/16	20	44
3531F				300																			
3551F				600																			
3562F				1 1/2	F	2	900		300	165	6 1/2	16	5/8	48	1 7/8	543	21 3/8	591	23 1/4	28	61		
3572F							1500																
3582F							2500																
3511G				1 1/2	G	3	150		150	121	4 3/4	124	4 7/8	16	5/8	35	1 3/8	448	17 5/8	515	20 1/4	25	55
3531G	300																						
3551G	600																						
3562G	2	G	3				900	300		165	6 1/2	16	5/8	48	1 7/8	543	21 3/8	591	23 1/4	27	59		
3572G							1500																
3582G							2500																
3511H	1 1/2	H	3				150	150		124	4 7/8	130	5 1/8	16	5/8	35	1 3/8	490	19 5/16	555	21 7/8	26	57
3531H				300																			
3531H				300																			
3551H				2	H	3	600		300	162	6 3/8	154	6 1/16	16	5/8	55	2 3/16	575	22 5/8	630	24 13/16	32	70
3562H							900																
3572H							1500																
3511J				2	J	3	150		150	124	4 7/8	136	5 3/8	17	11/16	38	1 1/2	490	19 5/16	555	21 7/8	28	62
3531J	300																						
3531J	300																						
3551J	600																						

type number (1st group)	inlet (ins)	orifice	outlet (ins)	ratings (ANSI)		overall dimensions*												approx. weights	
				inlet	outlet	A		B		C		D		E (max)					
						mm	in	mm	in	mm	in	mm	in	standard cap		lever cap			
														mm	in	mm	in	Kg	lbs
3561J	3	J	4	900	150	181	7 1/8	185	7 1/4	17	1 1/16	65	2 9/16	750	29 9/16	800	31 1/2	72	159
3572J				1500	300														
3511K	3	K	4	150	150	162	6 3/8	156	6 1/8	16	5/8	43	1 11/16	570	22 7/16	620	24 7/16	66	145
3531K				300															
3551K			600																
3561K			6	900															
3572K				1500		300													
3511L			3	L		4	150	150	165	6 1/2	156	6 1/8	16	5/8	43	1 11/16	570	22 7/16	620
3531L	300																		
3531L	4	6			181	7 1/8	179		7 1/16	20	13/16	50	2	630	24 13/16	685	27	88	194
3551L					203	8													
3561L					222	8 3/4	197		7 3/4			74	2 15/16	820	32 5/16	900	35 7/16	112	247
3571L					1500														
3511M	4	M	6	150	150	184	7 1/4	178	7	20	13/16	50	2	630	24 13/16	685	27	88	194
3531M				300															
3551M				600															
3551M				900															
3511N	4	N	6	150	150	210	8 1/4	197	7 3/4	20	13/16	50	2	820	32 5/16	900	35 7/16	102	225
3531N				300															
3551N				600															
3561N				900															
3511P	4	P	6	150	150	229	9	181	7 1/8	20	13/16	50	2	790	31 1/8	840	33 1/16	98	216
3531P				300															
3551P				600															
3561P				900															
3511Q	6	Q	8	150	150	241	9 1/2	240	9 7/16	22	7/8	57	2/14	890	35 1/16	970	38 3/16	180	397
3531Q				300															
3551Q				600															
3511R	6	R	8	150	150	241	9 1/2	240	9 7/16	22	7/8	57	2 1/4	890	35 1/16	970	38 3/16	190	419
3531R				300															
3531R			10	267		10 1/2	70	2 3/4	1045			41 1/8	1175	46 1/4	260	573			
3551R				600															
3511T	8	T	10	150	150	279	11	276	10 7/8	22	7/8	62	2 7/16	1100	43 5/16	1180	46 7/16	320	705
3531T				300															

*Refer to diagram on page 7

Installation: It is important that each valve is correctly installed in accordance with the API Recommended Practice 520 Part II.

Normal Maintenance

At regular intervals a precise check should be completed on the valve, also check for any visual signs of leakage. This is important especially when the process fluid is volatile or toxic.

If the valve is fitted with a lifting device the correct operation should be checked a minimum of twice a year.

During the tests the upstream pressure must be at least 75% of the valve set pressure.

Disassembly

- 1 Remove cap (3).
- 2 Mark the position of the spring adjusting screw (13) corresponding to the level of the lock nut (14) so that the same position may be regained during the calibration.
- 3 Remove blowdown ring clamping screw (16). Using a screwdriver, move blowdown ring until it touches the disc holder (moving from left to right) taking care to count and note the number of notches to regain the same position when calibrating.
- 4 Loosen the lock nut (14) of the

- spring adjusting screw (13).
- 5 Decompress spring (27) by loosening spring adjusting screw (13).
- 6 Remove bonnet (10) from body by unscrewing the nuts.
- 7 Remove upper spring carrier (17), spring (27) and lower spring carrier (17) from spindle (5).
- 8 Using the spindle as a handle, pull out the whole unit from the inside.
- 9 Remove pin (9) and unscrew stem (11) from disc holder (6).
- 10 Remove stem (11) from the guide tube (25).

- 11 Remove disc from disc holder. Place disc holder on a wooden surface and drive the disc out downwards.
- 12 Unscrew blowdown ring (8) in an anti clockwise direction.
- 13 Remove nozzle (2) from the valve body (1).

Assembly

Reassemble the valve carrying out the operations listed for the disassembly in reverse and taking care to:

- Avoid scratching on the lapped surfaces of the seat and disc.
 - Clean trim thoroughly throughout.
 - Spread with graphited grease on all threads, the stem and guide, adjusting screw and spring carrier.
 - For valves for oxygen service, carefully degrease all parts before mounting.
 - Check gaskets; if necessary replace them.
- After reassembling the valve proceed with testing.

A maintenance manual is supplied with each valve and further details are always available from our Technical Sales or Engineering departments.

Recommended spare parts

Disc - one disc for every four nozzles in service having the same orifice.

Spring - one spring for every four valves having the same orifice dimensions, material and set pressures.

Bellows - one bellows for every three bellows in service of the same orifice and valve dimensions. The threaded clamping nut and flange form part of the bellows.

Body Bonnet Joints - two sets for every three valves of the same dimensions.

Bonnet-Cap Joint - two for every three valves of the same dimensions.

• All Broady Series 3500 safety Relief Valves are sized using a dedicated sizing program, provided sufficient data is supplied at the enquiry stage by the customer. Upon request a copy of the Broady sizing program can be obtained by contacting the Technical Sales department.

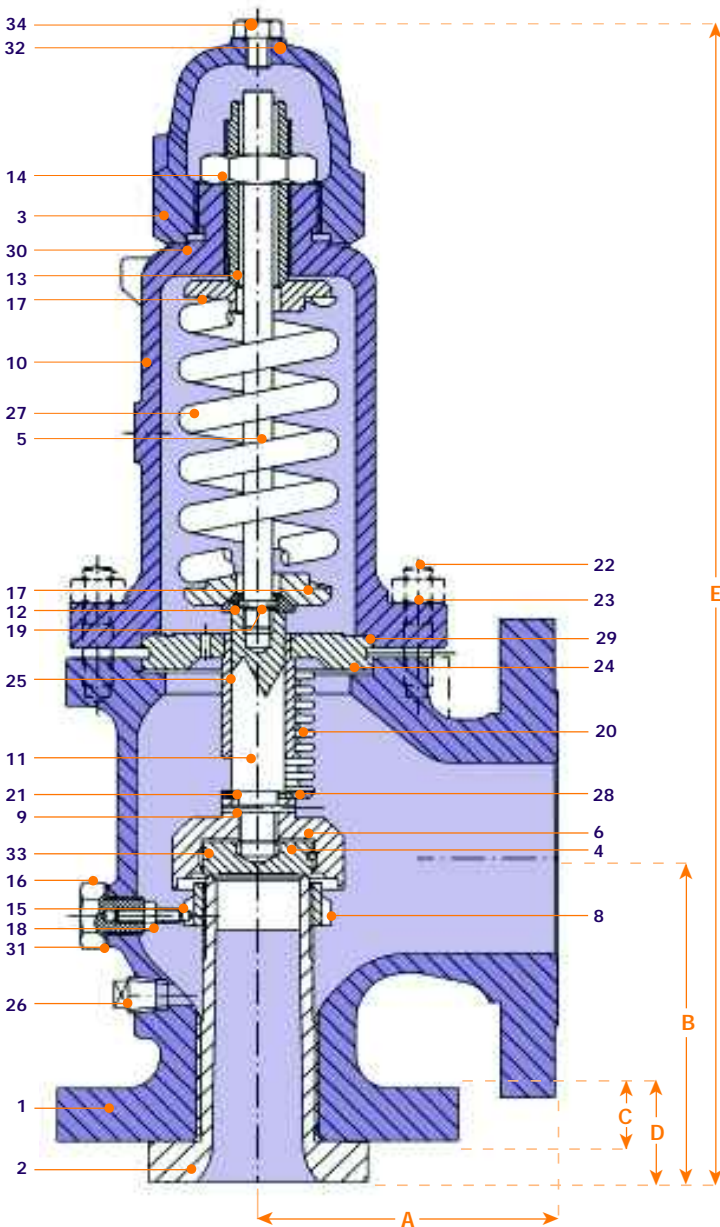

Parts key list

- | | |
|----|-----------------|
| 1 | body |
| 2 | nozzle |
| 3 | cap |
| 4 | disc |
| 5 | spindle |
| 6 | disc holder |
| 8 | blowdown ring |
| 9 | pin |
| 10 | bonnet |
| 11 | stem |
| 12 | collar |
| 13 | adjusting screw |
| 14 | locknut |
| 15 | screwed pin |
| 16 | clamped screw |
| 17 | spring carrier |
| 18 | locknut |
| 19 | pin |
| 20 | bellows |
| 21 | washer |
| 22 | stud |
| 23 | nut |
| 24 | guide flange |
| 25 | guide tube |
| 26 | drain plug |
| 27 | spring |
| 28 | joint |
| 29 | joints |
| 30 | joint |
| 31 | joint |
| 32 | joint |
| 33 | circlip |
| 34 | plug / gag |

Numbering system code: To simplify the selection and specifying of Safety Relief Valves, a numbering system is used in which the digits have a distinct significance.

EXAMPLES

1 A 2" ASA 300 inlet x 3" ASA 150 outlet, cast steel body, stainless steel trim with 'J' orifice, carbon steel spring, fitted with bellows and packed easing lever, closed bonnet, without test gag.
Number would be: 3531J-CB-020.

2 A 4" ASA 150 inlet x 6" ASA 150 outlet, all stainless steel construction with 'P' orifice, no bellows, no easing lever, closed bonnet, fitted with gag.
Number would be: 3511P-SN-001.

The first and second digit indicate the valve series.

35	3500
----	------

The third and fourth digit identify inlet and outlet ratings respectively for flanged valves.

third digit	inlet rating (ANSI)
1	150
3	300
5	600
6	900
7	1500
8	2500

fourth digit	outlet rating (ANSI)
1	150
2	300

The fifth digit identifies: the orifice for flanged valves.

fifth digit	orifice area (*)	
	sq. in.	cm ²
D	0.121	0.785
E	0.215	1.389
F	0.335	2.164
G	0.547	3.530
H	0.855	5.515
J	1.405	9.079
K	2.003	12.946
L	3.115	20.109
M	3.927	25.339
N	4.730	30.581
P	6.970	45.007
Q	12.060	77.913
R	17.420	112.663
T	28.400	183.281

The sixth digit identifies the body, bonnet and spring materials.

	body and bonnet	spring
S	A 351 CF8M stainless steel	stainless steel
L	A 352 LC1 alloy steel	stainless steel
C	A 216 WCB carbon steel	carbon steel
T	A 216 WCB carbon steel	Inconel
A	A 217 WC6 carbon steel	Inconel
M	BS3071 NA1 Monel	Inconel
GM	BS1400 LG2 Bronze	Inconel
AB	BS1400 AB2 Aluminium Bronze	Inconel

The seventh digit indicates the type of construction.

N	standard
B	balanced bellows

The eighth digit indicates whether the bonnet is open or closed.

0	closed
1	open

The ninth digit identifies the lifting device.

0	none
1	open lever
2	packed lever

The tenth digit refers to the gag.

0	without gag
1	with gag

How to order

To enable Broady Flow Control to offer the most suitable valve for your service please provide the following information at the enquiry stage:

- 1 Set Pressure
- 2 Back Pressure, built up or constant
- 3 Medium, with any relevant data, specific gravity or molecular weight etc.
- 4 Flowrate
- 5 Temperature
- 6 PED/CE Category*
- 7 Normal working pressure
- 8 Accumulation (10%, 21% or 25%)
- 9 Blowdown
- 10 Material requirements
- 11 Accessories, lifting lever etc.
- 12 Material Certification requirements
- 13 Any special testing requirements

The first six are required as a basic minimum to enable our sales team to proceed with a quotation.

*According to the Pressure Equipment Directive (PED) Safety Valves are categorised as a safety accessory and as such the normal level is category IV, unless the system to which they are to be fitted is of a lower level in which case the lower level should be used. The PED is only applicable to Countries within the European Union.

Applications: Broady safety valves are used in many applications, including shipbuilding, the oil and gas industry, chemical and power generation and fire protection.



Valve Testing.

A state of the art flow test rig was purpose built using the guidelines stipulated within ASME to evaluate each size of valve. The test rig is computer controlled with full data logging capability.



Valves from the Broady range.



Reducing Valves – A, AB, CL, CN, CH,
D, B2



Fire Fighting – Hydrant Reducing Valves



Other Safety Relief Valves – 180 & 180S, 2600



Low Pressure Reducing Valves – CL



Sustaining Valves – Type A, Type D, Type 9



Pilot Operated Safety Valves – Flowsafe

• Speciality casting from in-house foundry in non-ferrous metals • The Series 3500 Safety Relief valve has been combination flow tested with bursting discs from continental (CDC) Disc Corporation • Full repair facilities.

Broady Flow Control Limited

English Street
Kingston upon Hull
East Yorkshire
HU3 2DU

telephone: +44 (0) 1482 619600

facsimilie: +44 (0) 1482 619700

email: sales@broady.co.uk

website: www.broady.co.uk

Singapore Sales Enquiry:
Email: sales@pipeline.com.sg
Tel: (65) 6570 0310

Myanmar Sales Enquiry:
Email: sales@pipeline-mm.com
Tel: (95) 9509 5758

